

mody

ELECTRIC SUBMERSIBLE DRAINAGE PUMP

M-500/530/550 SERIES

**PORTABLE ELECTRIC
SUBMERSIBLE PUMP FOR
CORROSIVE & ABRASIVE
APPLICATIONS**

.....
5 HP (3.7kW)

M 502T / M 504T / M 506T

4"(100mm) / 4"(100mm) / 3"(75mm) NPT or Hose
.....

7.5 HP (5.5kW)

M 530T / M 536T

4"(100mm) / 3"(75mm) NPT or Hose
.....

10 HP (7.5kW)

M 554T / M 556T

4"(100mm) / 3"(75mm) NPT or Hose
.....



M-500/530/550 DESIGN ADVANTAGES

- Stainless Steel Strainer, Shaft, Impeller, Outlet and Hardware for maximum corrosion resistance.
- Choice of impeller materials:
 - 1) 316 Stainless Steel for sea water and corrosive applications and;
 - 2) Nitride Hardened 410 Stainless Steel for abrasive applications. (Standard)
- Tandem Tungsten Carbide/Tungsten Carbide and Tungsten Carbide/Tungsten Carbide mechanical seals.
- Mechanical Seals in wholly enclosed pressure compensated oil chamber.
- Field adjustable Nitrile Rubber-lined Diffuser/Wear Plate Optimizes efficiency throughout the life of the pump. Polyurethane Diffusers and Wear Plates are available.
- Automatic ON/OFF/ON Thermal Overloads embedded in Stator Winding Optional - requires 6 core cable and external controls or optional built-in contactor with 4 core cable.
- Seal Probe Sensor Option available. Requires external controls.
- 1 meter long SS Sheath protects the power cable in demanding mine applications.
- Equipped with Sacrificial Zinc Anodes for maximum life in a saline fluid environment.

Mody Pumps® Inc.
2166 Zeus Court, Bakersfield, CA 93308. USA
Tel.: (661) 392-7600 • Fax: (661) 392-7601
<http://www.modypump.com>
E-mail: sales@modypump.com

mody ELECTRIC SUBMERSIBLE DRAINAGE PUMP

M-500/530/550 SERIES

5HP (3.7kW) / 7.5HP (5.5kW) / 10HP (7.5kW)

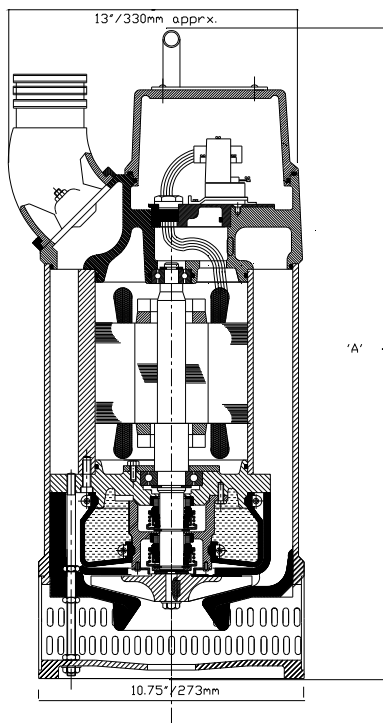

MODEL 'A'

M-500	29.5" (750mm)
M-530	32.5" (825mm)
M-550	33.0" (850mm)

M-500/530/550 SERIES

MATERIALS OF CONSTRUCTION AND ENGINEERING DATA

MOTOR

2-pole induction **continuous rated** motor with squirrel cage rotor.
 Stator insulation class 'H' (180°C)
 Speed : 3400 RPM @ 60 Hz, 2800 RPM @ 50 Hz
 Power Rating : 5HP/7.5HP/10HP @ 60 Hz, 3.7kW/5.5kW/7.5kW @ 50Hz Full Load
 Current FLA: 7.1, 11, 14 Amps @ 460v. 8.1, 12.5, 16 @ 400v.
 Max. temperature of the pump liquid : 104°F/40°C
 Max. start/stop per hour : 15

POWER SUPPLY

3 phase, 50/60 Hz, AC Supply. Available in any voltage frequency combination. (208/220/230/380/415/460/575/1000V)

BALL BEARINGS

The rotor shaft is carried in two single row, deep groove ball bearings.
 The bearings are enclosed with high temperature grease-containing special Anti-corrosion additive.

POWER CABLE

Waterproof/oil proof, rubber-insulated, neoprene-sheathed copper conductor flexible cable, 50ft. (15m) length standard. Type SOOW in North America, EPR in the Middle East and HO7RN in the EU. 6 Core with thermal overloads optional.

SHAFT SEAL

Tandem Tungsten Carbide/Tungsten Carbide and Tungsten Carbide/Tungsten Carbide Mechanical seals wholly enclosed in a pressure compensated oil chamber.

CORROSION RESISTANT

Epoxy coated Aluminum Outer Casing
 Epoxy coated Extruded Aluminum Stator Casing
 Nitrile Rubber- Lined Diffuser/Wear plate. Polyurethane Optional.
 Shaft: 431 Stainless Steel
 Hardware: 304 Stainless Steel
 Impeller: Nitride Hardened 410SS to 56HRC is Standard.
 pH Range 5 - 8

STRAINER

304 Stainless Steel with 1" (25mm) X 1/4" (6mm) {M 502/504},
 1-3/16" (30mm) X 3/8" (9.5mm) {M530/554},
 1/4" (6mm) Round Holes {M 506/536/556}

SUBMERGENCE

Submergence below liquid surface min 5" (127mm) max. 50' (15m).

WEIGHTS (Approx. without cable)

M 502/504:	110lbs. (50Kg)
M 506:	115lbs. (52Kg)
M 530:	130lbs. (59Kg)
M 536:	135lbs. (61Kg)
M 554:	142lbs. (64Kg)
M 556:	147lbs. (67Kg)

PERFORMANCE CURVES

MODEL: M 502/504/506/530/536/554/556 (50/60 Hz)

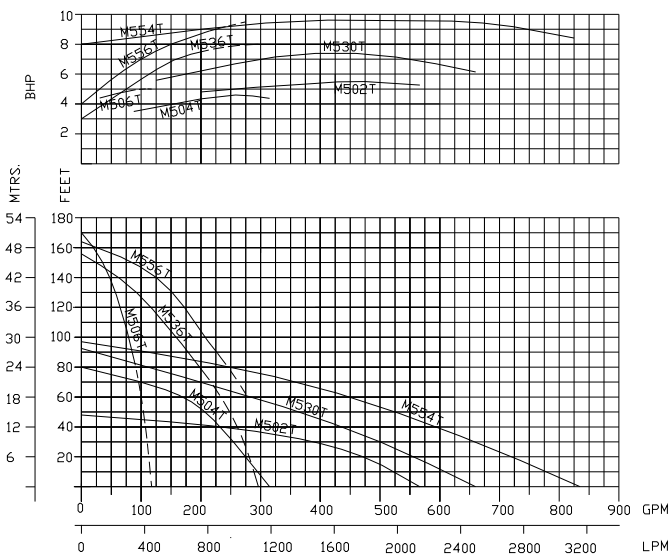

Due to continuous product development, specifications are subject to change without notice.

03.10.Rev.0