

Hydraulic pump

HY300A/B



PUMP SPECIFICATIONS	Mod. A	Mod. B
Capacity [m ³ /h - (USGPM)]	900 - (3960)	1200 - (5280)
Head [m - (ft)]	34 - (112.2)	26 - (84.5)
Impeller diameter [mm - (in)]/type	760 - (30.4)/2 blades closed	
Flanged bore size [DN.../PN... - (in)]	250 - (10)	300 - (12)
Cross section diameter [mm - (in)]	120 - (4.8)	
Weight [kg - (lbs)]	3500 - (7700)	3550 - (7810)

HYDRAULIC MOTOR	
Motor displacement [cc - (cu in)]	500 - (30)
Max. oil flow rate[l/min - (USGPM)]	380 - (1672)
Max. pressure [bar - (psi)]	300 - (4350)
Power [kW-HP]	190-260
Speed [RPM]	750

MATERIALS	
Casing	Spheroidal cast iron EN-GJS-500-7 (EN 1563)
Motor housing	Cast iron EN-GJL-250 (EN 1561)
Wear parts	High chrome EN-GJN-HV600 (XCr18) (EN 12513)
Main shaft	High tensile steel 39NiCrMo3 (AISI 9840)

SEALS / LUBRICANT	
Motor side seals	3 lip seals (2 BUNA + 1 PTFE)
Impeller side seals	5 lip seals (3 BUNA + 2 PTFE)
Oil type	ISO 320

DIMENSIONS [mm - (in)]							
H	W	D	F	H1	A	B	C
2400	1600	1357	1015	470	652	750	576
(96)	(64)	(54.3)	(42)	(18.8)	(26.1)	(30)	(23)

PERFORMANCE CURVES

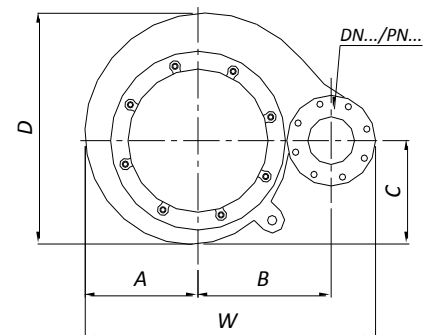
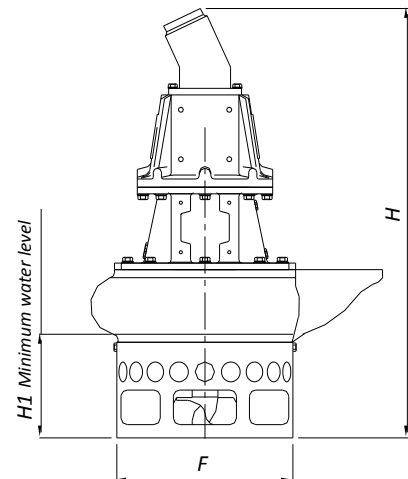
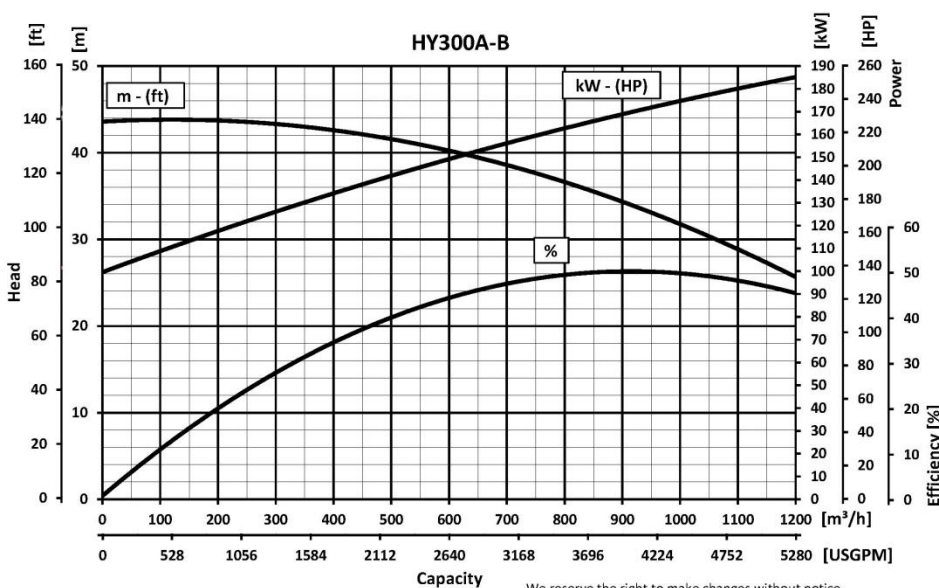

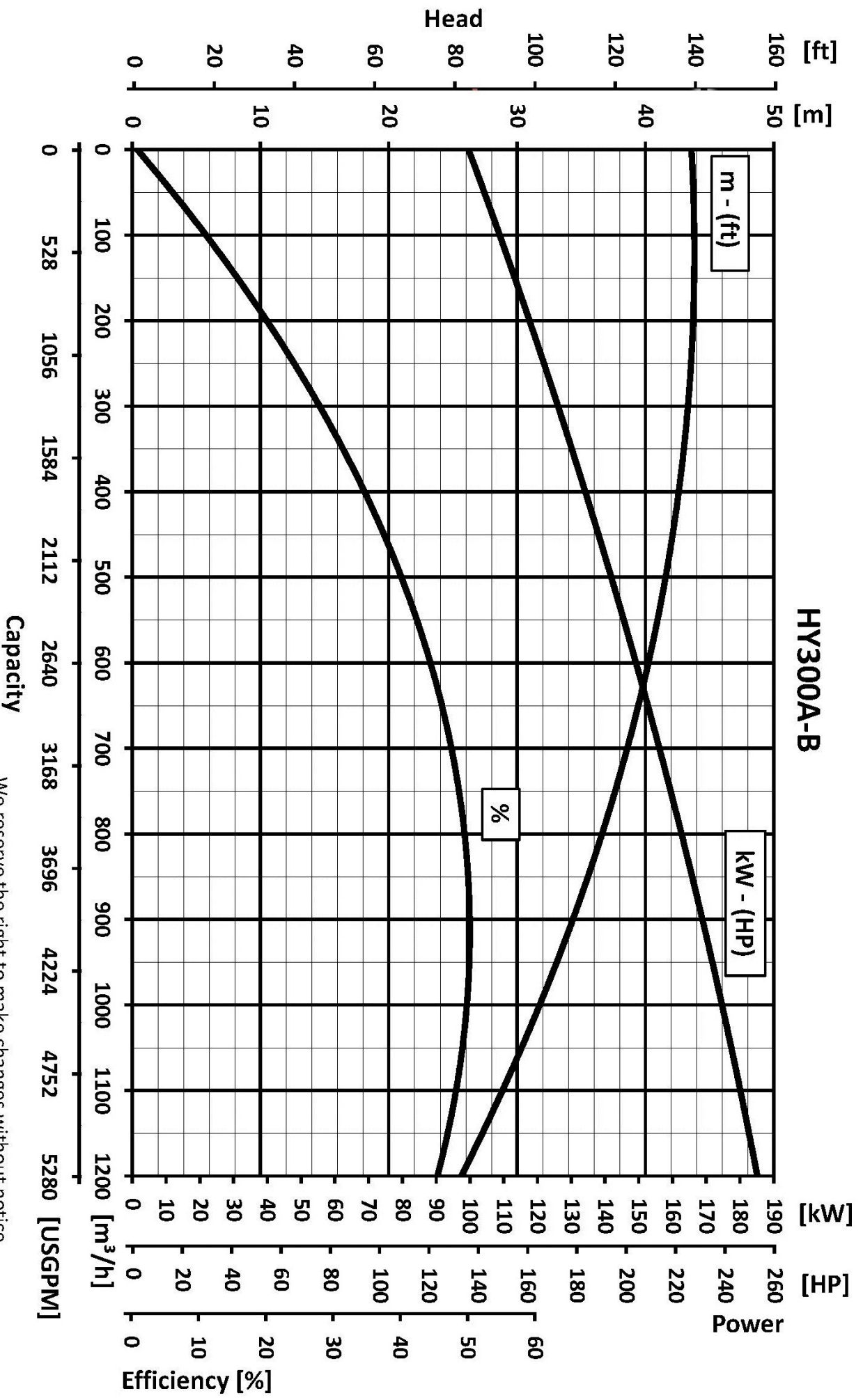

Capacity

We reserve the right to make changes without notice