

# Hydraulic pump

## HY50A/B



PUMP SPECIFICATIONS	Mod. A	Mod. B
Capacity [m <sup>3</sup> /h - (USGPM)]	110 - (484)	170 - (748)
Head [m - (ft)]	44 - (143)	38 - (123.5)
Impeller diameter [mm - (in)]/type	490 - (19.6) /2 blades closed	
Flanged bore size [DN.../PN... - (in)]	100 - (4)	150 - (6)
Cross section diameter [mm - (in)]	35 - (1.4)	
Weight [kg - (lbs)]	600 - (1320)	610 - (1342)

HYDRAULIC MOTOR	
Motor displacement [cc - (cu in)]	75 - (4.5)
Max. oil flow rate [l/min - (USGPM)]	89 - (396)
Max. pressure [bar - (psi)]	300 - (4350)
Power [kW-HP]	45-60
Speed [RPM]	1180

MATERIALS	
Casing	Spheroidal cast iron EN-GJS-500-7 (EN 1563)
Motor housing	Cast iron EN-GJL-250 (EN 1561)
Wear parts	High chrome EN-GJN-HV600 (XCr18) (EN 12513)
Main shaft	High tensile steel 39NiCrMo3 (AISI 9840)

SEALS / LUBRICANT	
Motor side seals	2 lip seals (BUNA)
Impeller side seals	3 lip seals (BUNA) + 1 V-RING (TPU)
Oil type	ISO 320

DIMENSIONS [mm - (in)]							
H	W	D	F	H1	A	B	C
1330	902	774	600	274	374	418	363
(53.2)	(36.8)	(31)	(24)	(11)	(15)	(16.8)	(14.5)

### PERFORMANCE CURVES

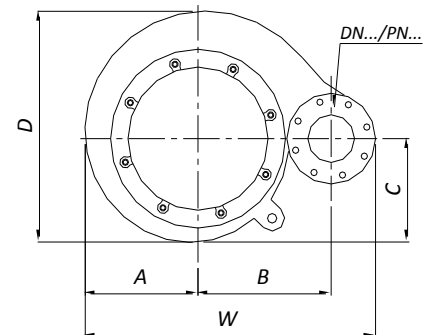
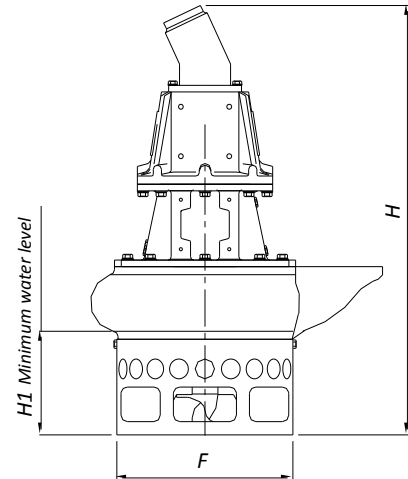
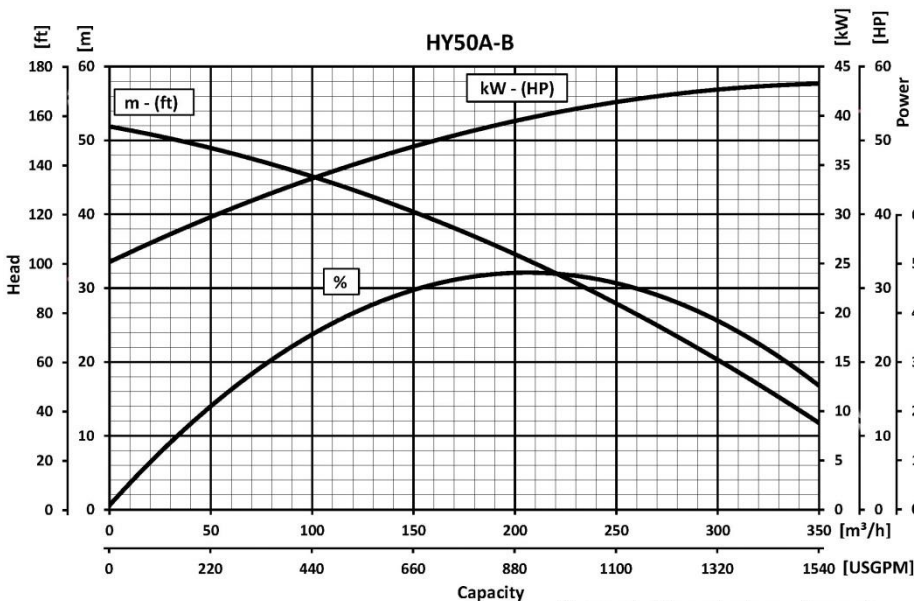

We reserve the right to make changes without notice.

**DRAGFLOW**  
ULTIMATE EFFICIENCY

# HY50A-B

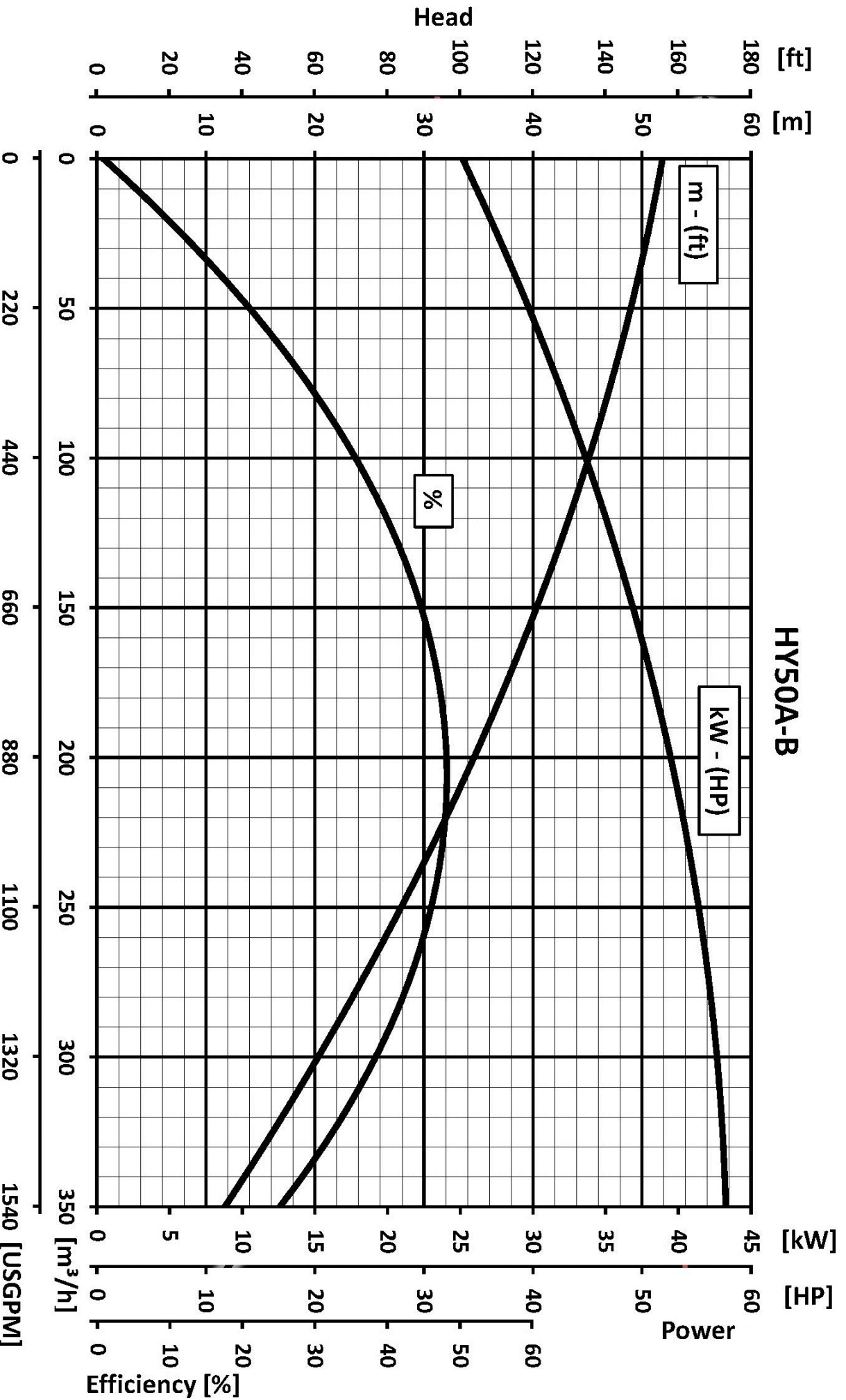

We reserve the right to make changes without notice