

Hydraulic pump

HY85/160A/B



PUMP SPECIFICATIONS	Mod. A	Mod. B
Capacity [m ³ /h - (USGPM)]	250 - (1100)	460 - (2024)
Head [m - (ft)]	56 - (182)	48 - (156)
Impeller diameter [mm - (in)]/type	440- (17.6)/3 blades closed	
Flanged bore size [DN.../PN... - (in)]	200- (8)	250- (10)
Cross section diameter [mm - (in)]	60- (2.4)	
Weight [kg - (lbs)]	820 - (1540)	840 - (1606)

HYDRAULIC MOTOR	
Motor displacement [cc - (cu in)]	160 - (9.8)
Max. oil flow rate[l/min - (USGPM)]	240- (1090)
Max. pressure [bar - (psi)]	300- (4350)
Power [kW-HP]	120-165
Speed [RPM]	1450

MATERIALS	
Casing	Spheroidal cast iron EN-GJS-800-2 (EN 1563)
Motor housing	Cast iron EN-GJL-250 (EN 1561)
Wear parts	High chrome EN-GJN-HV600 (XCr18) (EN 12513)
Main shaft	High tensile steel 39NiCrMo3 (AISI 9840)

SEALS / LUBRICANT	
Motor side seals	2 lip seals (BUNA)
Impeller side seals	5 lip seals (3 BUNA + 2 PTFE) + 1 V-RING (TPU)
Oil type	ISO 320

DIMENSIONS [mm - (in)]							
H	W	D	F	H1	A	B	C
1390	933	747	548	290	362	428	334
(55.6)	(37.3)	(29.9)	(21.9)	(11.6)	(14.5)	(17.1)	(13.4)

PERFORMANCE CURVES

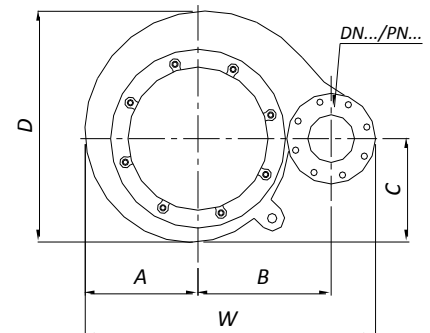
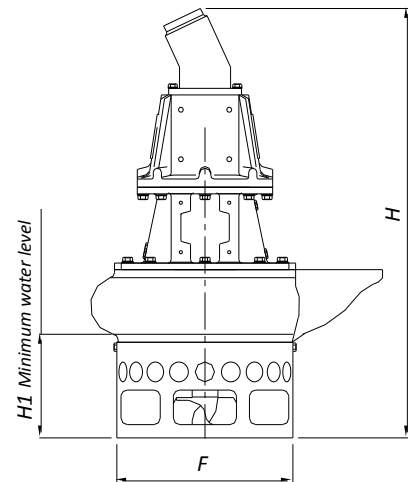
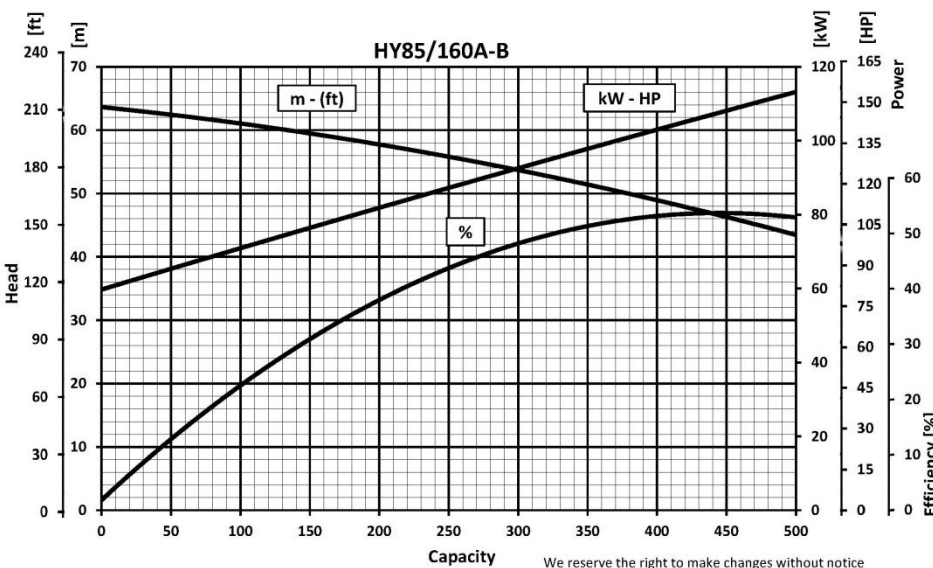

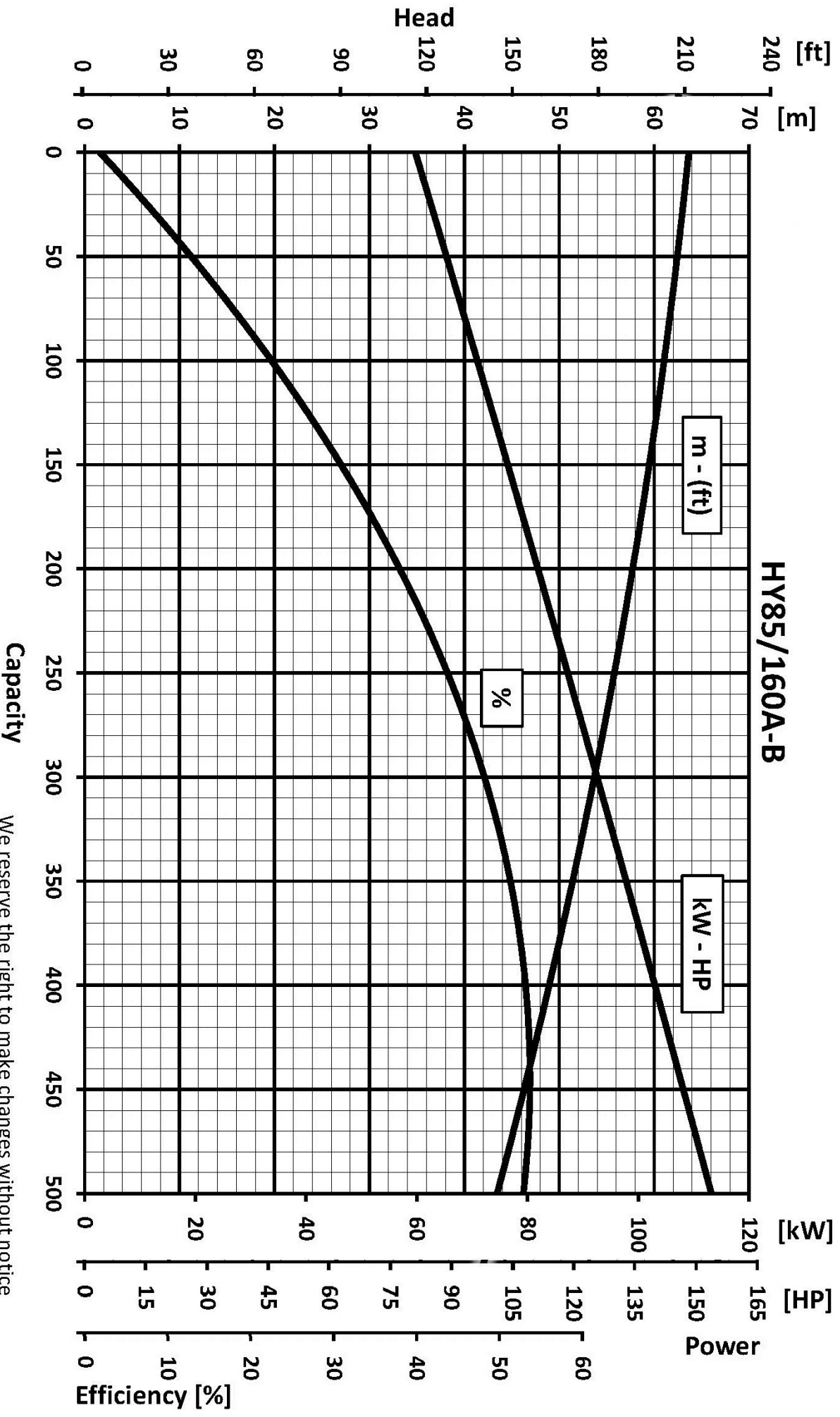

Capacity

We reserve the right to make changes without notice