

Hydraulic pump

HY85HC

PUMP SPECIFICATIONS

Capacity [m ³ /h - (USGPM)]	620 - (2728)
Head [m - (ft)]	16 - (52)
Impeller diameter [mm - (in)]/type	405- (16.2)/3 blades closed
Flanged bore size [DN.../PN... - (in)]	250- (10)
Cross section diameter [mm - (in)]	90- (3.6)
Weight [kg - (lbs)]	1030- (2266)

HYDRAULIC MOTOR

Motor displacement [cc - (cu in)]	108- (6.5)
Max. oil flow rate[l/min - (USGPM)]	130- (572)
Max. pressure [bar - (psi)]	300- (4350)
Power [kW-HP]	65-90
Speed [RPM]	1180

MATERIALS

Casing	Spheroidal cast iron EN-GJS-500-7 (EN 1563)
Motor housing	Cast iron EN-GJL-250 (EN 1561)
Wear parts	High chrome EN-GJN-HV600 (XCr18) (EN 12513)
Main shaft	High tensile steel 39NiCrMo3 (AISI 9840)

SEALS / LUBRICANT

Motor side seals	2 lip seals (BUNA)
Impeller side seals	5 lip seals (3 BUNA + 2 PTFE) + 1 V-RING (TPU)
Oil type	ISO 320

DIMENSIONS [mm - (in)]

H	W	D	F	H1	A	B	C
1470	1165	1020	548	326	478	485	449
(58.8)	(46.6)	(40.8)	(21.9)	(13)	(19.1)	(19.4)	(18)

PERFORMANCE CURVES

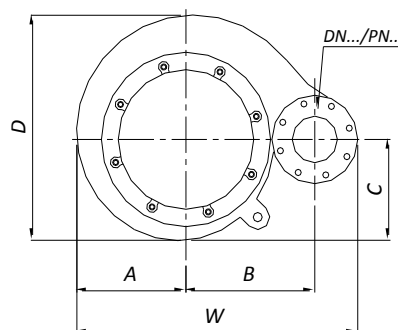
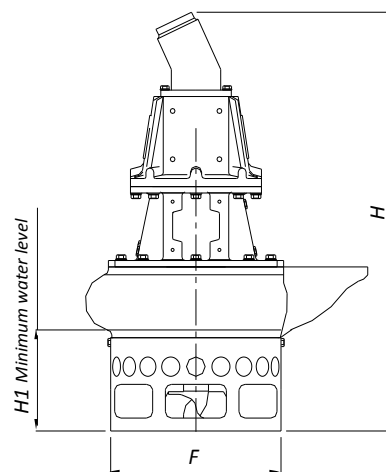
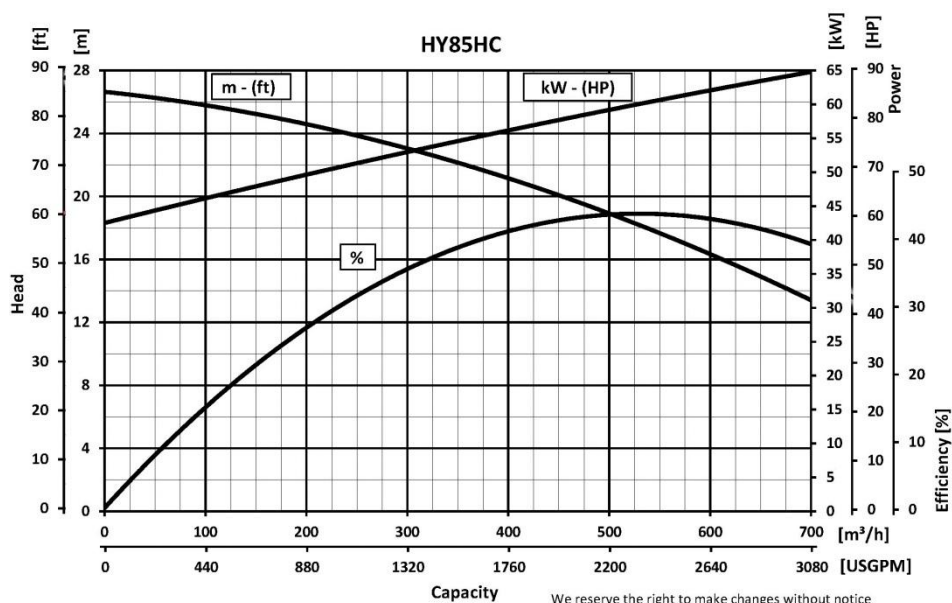

HY85HC

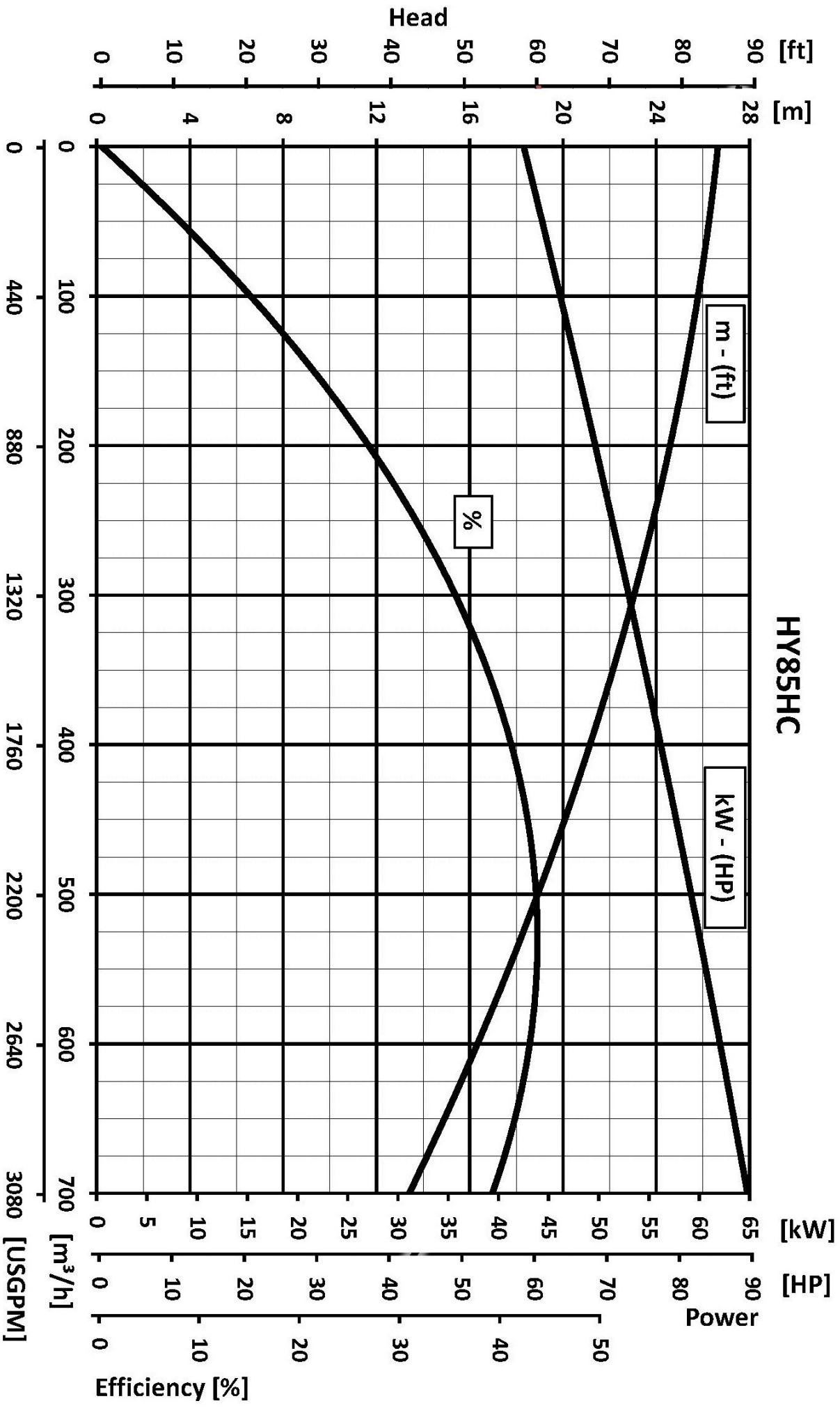

Capacity

We reserve the right to make changes without notice